

Manual de Usuario

Sensor movimiento y luminosidad IR KOOB, empotrado

Welcome to use infrared motion sensor!

The product adopts good sensitivity detector, integrated circuit. It gathers automatism, convenient safe, saving-energy and practical functions. It utilizes the infrared energy from human as control-signal source, it can start the load at once when one enters detection field. It can identify day and night automatically. It is easy to install and used widely.

SPECIFICATION:

Power Sourcing: 220V/AC-240V/AC

Power Frequency: 50/60Hz

Ambient Light: <10-2000LUX (Adjustable)

Time-Delay: min.10sec±3sec

Max.7min±2min

Rated Load: 1200W (incandescent lamp)

300W (energy-saving lamp)

Detection Distance: 8m max (<24 °C)

Detection Range: 360°

Working Temperature: -20~+40 °C

Working Humidity: <93%RH

Installing Height: 2.2m~4m

Power Consumption: <0.9W (work)

<0.9W (static)

Detection Motion Speed: 0.6~1.5m/s

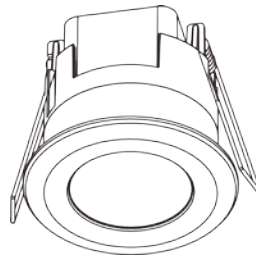

FUNCTION:

- Identify day and night automatically. Can adjust ambient light according to your desire: when turn to SUN (max), it will work in the daytime and at night. When turn to MOON (min), it will only work under less than 10LUX circumstance. As for Adjustment, please refer to testing way.
- Time-delay is added continually: when it receives the second induction signal after the first inductor, it will compute time once more on the rest of the first time-delay basic (Set time) .
- Time-delay adjustment: it can be set according to your desire. The minimum is 10±3 sec; the maximum is 7±2min.

INSTALLATION: (as following drawing.):

- Turn off the power.
- Moving the transparent vinyl cover what is in the bottom of the sensor.
- Loosing the screws in the connection terminal, connecting the power and rated load to connection terminal of sensor according to connection sketch map.
- Tighten the screws; put the transparent vinyl cover into the original station.
- Folding the metal spring of the sensor to upwards, until they are "I" position with sensor, then put the sensor into the hole or installation box what is in the ceiling, the size is similar with item. Releasing the spring, the sensor will be set in this installation position.
- After finishing installing, the sensor could be connected the power and testing it.

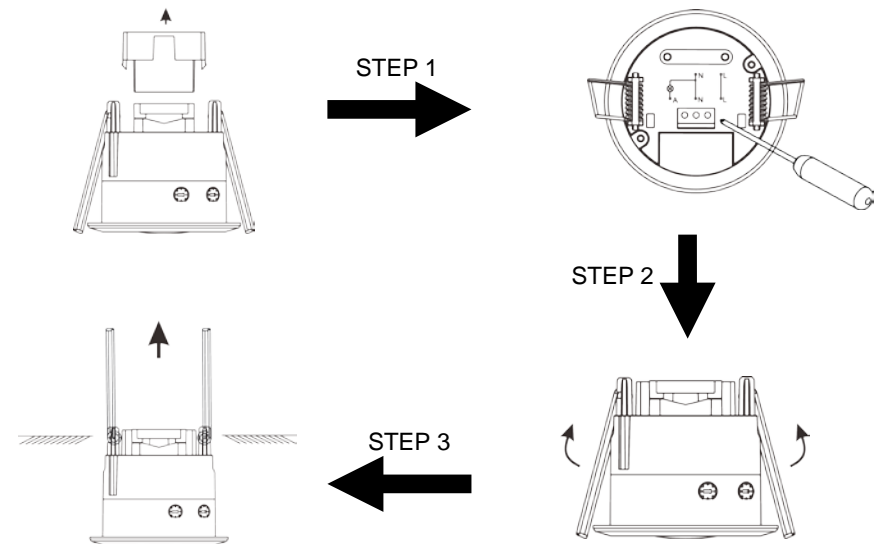

CONNECTION SKETCH FIGURE:

(As per right drawing)

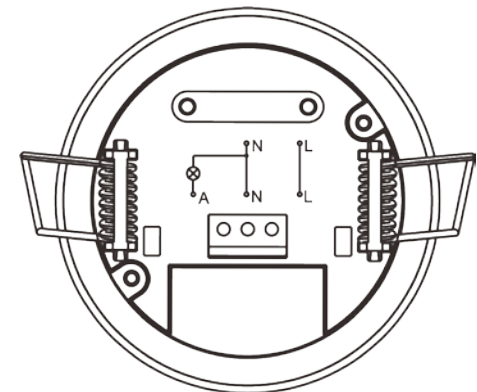

TEST:

- Turn the TIME knob anti-clockwise on the minimum, turn the LUX knob clockwise on the maximum (sun).
- Turn on the power, the sensor will be electrify and warm-up, 30 sec later, the item will be entered into working estate.
- 5~10 seconds after the light goes out for the first time and then sensing, the load should be worked.
- Turn LUX knob anti-clockwise on the minimum (moon). The inductor load should not work after load stop working. If you cover the detection window with the opaque objects (towel etc), the load work .under no induction signal condition, the load should stop working within 5-15sec.

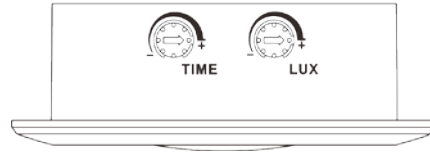

Note: when testing in daylight, please turn LUX knob to ☀ (SUN) position, otherwise the sensor lamp could not work!

NOTE:

- Should be installed by electrician or experienced man.
- Avoid installing it on the unrest objects.
- There shouldn't be hindrance and moving object in front of the detection window effecting detection.
- Avoid installing it near air temperature alteration zones such as air condition, central heating, etc.
- Considering your safety, please don't open the cover when you find the hitch after installation.

SOME PROBLEM AND SOLVED WAY:

- The load don't work:
 - a. Please check the power and load connect is correct.
 - b. Check if the load is good.
 - c. Check if the working light corresponds to the ambient light.
- The sensitivity is poor:
 - a. Please check if there is hinder in front of the detection window to effect receiving the signals.
 - b. Please check if the ambient temperature is too high.
 - c. Please check if the signals source is in the detection fields.

d. Please check if the installation height corresponds to the height showed in the instruction.

- The sensor can't shut the load automatically:
 - a. Check if there are continual signals in the detection fields.
 - b. Check if the time delay is set to the longest.
 - c. Check if the power corresponds to the instruction.
 - d. Check if the temperature change obviously nears the sensor, such as air condition or central heating etc.